

Ruwac USA Industrial Vacuums

Red Line

Installation, Operation, Maintenance & Service

Model No.

Serial No.

Filter No.

Start-Up Date

• PORTABLE

• DIRECT BAGGING

• SILO SYSTEMS



Version: 2.5 4/27/20

Contents	Page
I. Warranty	3
II. Safety	3
III. Start-Up	5
• Filter Inspection	6
IV. Inspection and Maintenance	
• Filter Removal	7
• Filter Installation	8
• HEPA Installation	9
• Floor Sweep Installation	13
• Motor Brush Inspection	14
• Direct Bagging Instructions	18
• Silo Vacuum Instructions	19
V. Trouble Shooting	20
VI. Terms and Conditions	21

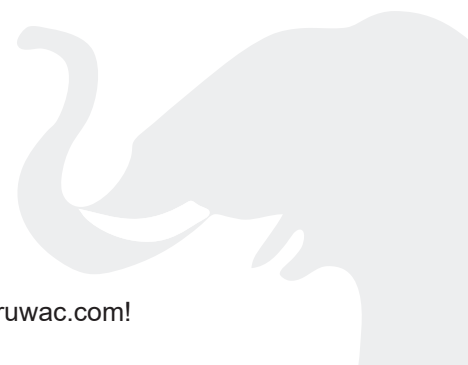

I. Warranty

RUWAC warrants that new equipment which are complete units and are sold and/or manufactured by RUWAC, Inc. will be free from defects in material and workmanship for a period of 18 months from date of shipment or 12 months from date of start-up, whichever come first. RUWAC warrants that replacement parts sold hereunder will be free from defects in material or workmanship for a period of 120-days after the date of shipment. RUWAC machines that have been completely re-built at the factory will carry a 180-day warranty from date of shipment. All field repairs preformed by authorized RUWAC service personnel are covered by a 120-day parts only warranty.

RUWAC, Inc. will not assume any responsibility under the terms of this limited warranty on equipment, which has not been paid in full. This warranty does not apply to any equipment that has been disassembled, repaired, or otherwise altered by any person without the written authorization of RUWAC'S service department, nor does it apply to any product that has been subjected to failure sure to corrosive or abrasive attack, misused, damaged, or improperly installed, nor does it apply to motors, controls, and components not manufactured by RUWAC, Inc. Motors, controls, and other Sub vendor's components therefor are warranted only to the extent of the manufacture's warranty. All warranty work on such products must be authorized by RUWAC, Inc. and must be performed in an authorized shop as designated by the manufacturer. RUWAC sole liability and buyer's sole and exclusive remedy hereunder is the replacement or repair at RUWAC'S option of products not complying with this warranty. Such repair or replacement shall be F.O.B. RUWAC'S factory, and RUWAC reserves the right to invoice all expenses incurred when repairs are made in the field at the request of the customer, except as specifically set forth herein, RUWAC makes no warranty express or implied, with respect to the products and/or service supplied hereunder, this warranty is in lieu of and excludes all other warranties, including without limitation, any warranty of merchantability, fitness for a particular purpose, or conformance to purchaser's specifications.

II. Safety

CAUTION: Ruwac Red Line machines are not to be used for the removal of liquids or any volatile, viscous, flammable or explosive media. If you are unsure about your application requirements consult your Ruwac representative.

CAUTION: Ruwac Red Line machines are designed for intermittent use, i.e. not more then 2 hours continuously. If you are unsure about your application requirements consult your Ruwac representative.

CAUTION: A dust mask should be worn when working with used filters.

CAUTION: Disconnect the machine from the power source before and during inspection and/or maintenance.

CAUTION: Machines equipped with a reverse pulse module must always be supplied adequately when the machine is on. The module is controlled by an electrical sequential timer (requires a 110 , 220 or 240 volt power supply) or differential pressure switch. The module itself requires a source of compressed air of 90 PSI at 2-4 CFM (depending on module). This device prevents the accumulation of material on the filter and therefore prevents the machine's operation from being interrupted due to material blockage.

CAUTION: Machines equipped with a motorized shaker must be supplied with a three phase, 230-460 volt (depending on motor) power supply when ever the machine is on. The motorized shaker is controlled by an electrical sequential timer (requires a 110 volt power supply), a differential pressure switch or a manual switch. Manual switch models should be actuated before and after every use while the vacuum is off. This device prevents the accumulation of material on the filter and therefore prevents the machine's operation from being interrupted due to material blockage.

CAUTION: Hoses and accessories must be checked for continuity prior to each use when used in a hazardous application (i.e. combustible materials or environment).

IMPORTANT SAFETY INSTRUCTIONS (cont'd)

CAUTION

- 1) USE ONLY RUWAC REPLACEMENT PARTS, ACCESSORIES AND HOSES SPECIFICALLY DESIGNED FOR YOUR MACHINE.
- 2) FOR SAFE USE SEE OPERATORS MANUAL
- 3) CLEAN UNIT DAILY
- 4) DO NOT USE WITH FLAMMABLE LIQUIDS, VAPORS OR ON SOLIDS CONTAMINATED WITH FLAMMABLE LIQUIDS.
- 5) DO NOT INSTALL WHERE THE MAXIMUM TEMPERATURE EXCEEDS THE IGNITION TEMPERATURE OF THE HAZARDOUS ATMOSPHERE(S)
- 6) TO PREVENT IGNITION OF HAZARDOUS ATMOSPHERES, DISCONNECT FROM THE POWER SUPPLY CIRCUIT BEFORE OPENING ENCLOSURE. KEEP TIGHTLY CLOSED WHILE CIRCUITS ARE LIVE.
- 7) DISCONNECT ELECTRICAL SUPPLY BEFORE SERVICING OR REPLACING FILTER.
- 8) TO REDUCE RISK OF ELECTRIC SHOCK DO NOT USE ON WET SURFACES. DO NOT EXPOSE TO RAIN. STORE INDOORS.
- 9) IF CONNECTED TO A CIRCUIT PROTECTED BY FUSES, USE TIME DELAY FUSES MARKED TYPE "D" WITH THIS APPLIANCE.
- 10) ANY MODIFICATIONS TO THIS UNIT VOIDS WARRANTY.

AVERTISSEMENT

- 1) N'UTILISER QUE DES PIÈCES DÉTACHÉES ET ACCESSOIRES SPÉCIALEMENT CONÇUS POUR LA MARQUE RUWAC.
- 2) POUR VOTRE SÉCURITÉ, PRENEZ CONNAISSANCE DU MANUEL D'INSTRUCTION.
- 3) NETTOYEZ LA MACHINE JOURNELLEMENT.
- 4) NE PAS UTILISER PRÈS DES MATIÈRES INFLAMMABLES.
- 5) NE PAS UTILISER DANS DES LIEUX A ATMOSPHÈRES DANGEREUSE OÙ LA TEMPÉRATURE EST SUPÉRIEURE A LA TEMPÉRATURE D'IGNITION.
- 6) POUR ÉVITER L'IGNITION EN ATMOSPHÈRE DANGEREUSE, DÉBRANCHER LA PRISE ÉLECTRIQUE AVANT D'OUVRIER LE COUVERCLE. GARDER LE COUVERCLE FERMÉ LORSQUE LES CIRCUITS SONT SOUS TENSION.
- 7) DÉBRANCHER DE TOUTE SOURCE ÉLECTRIQUE AVANT TOUTE INTERVENTION OU REMPLACEMENT DU FILTRE.
- 8) POUR ÉVITER LES RISQUES D'ÉLECTROCUTION, NE PAS UTILISER EN ATMOSPHÈRE HUMIDE. NE PAS EXPOSER A LA PLUIE ET GARDER A L'INTÉRIEUR.
- 9) SI CONNECTÉ À UN CIRCUIT PROTÉGÉ PAR DES FUSIBLES, UTILISEZ DES FUSIBLES TEMPORISÉS DE TYPE « D » AVEC CET APPAREIL.
- 10) TOUTE INTERVENTION PAR UN TECHNICIEN NON QUALIFIÉ PAR RUWAC ANNULERA LA GARANTIE.

SAVE THESE INSTRUCTIONS



**RED LINE STANDARD INSTRUCTIONS:
START-UP / SHUTDOWN OPERATION**

NOTE: A qualified electrician in accordance with the National Electric Code and all local codes should perform all wiring and / or electrical adjustments during installation and servicing.



1 Pull up on the dust pan lever to release the dustpan. Check that the dustpan is completely empty then replace.



2 Connect the machine to the proper power source, as indicated on the machine's serial tag.

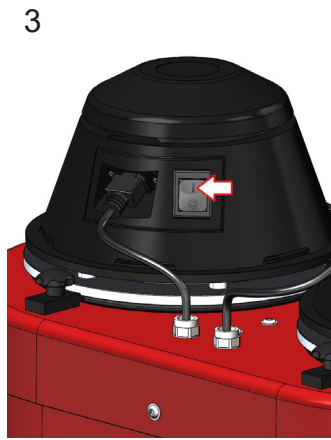

3 Turn the machine on and off by using the power switches.

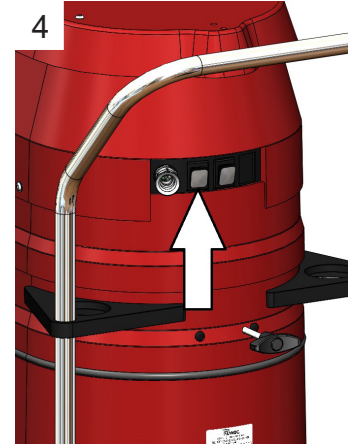

4 When operating a vacuum with multiple motors, turn on the motors one at a time, allowing 2 seconds in between starting each motor.



5 Before and after every use, the filter should be shaken by moving the shaker bar in and out rapidly for 10 seconds.

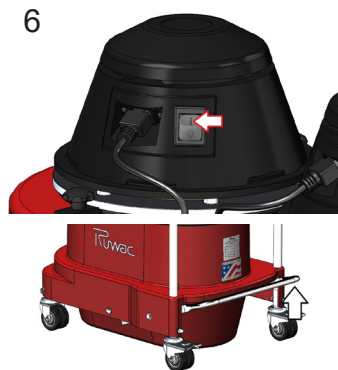

6 Release the dustpan, and turn the machine ON / (I).



7 You should empty the dustpan after every use as well.*

***SEE PAGE 14 FOR
DIRECT BAGGING
EMPTYING
INSTRUCTIONS**

**SEE PAGE 15 FOR
SILO VACUUM
EMPTYING
INSTRUCTIONS**

CAUTION: The electrical service at the installation site must supply the voltage stamped on the machine's serial tag. Most motors have multiple voltage capabilities that may appear on the motor tag but do not apply to the specific machine. Operating at an incorrect voltage may damage the machine. See the Ruwac serial tag for proper machine voltage.

**RED LINE STANDARD INSTRUCTIONS:
FILTER INSPECTION**

WARNING: Always wear a dust mask when performing filter inspections or service.



With machine off, knock material off the filter via the manual shaker by moving it in and out rapidly for 10 seconds.



Pull up on the dust pan lever to release the dustpan to the floor, and remove the dustpan.



Lock the rear casters. Carefully tip the machine back onto the push handle in order to inspect the filter.



Remove any material between the pleats, by hand only. Inspect the pleats of the filter for tears and material blockage; Inlet for wear.



Vacuum off any excess material with another vacuum, making sure not to use any sharp tools that may tear the filter.

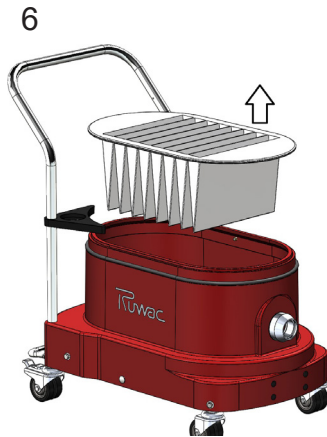

Replace filter as required or if the filter shows signs of staining, tears or holes. (See pg. 6 for instructions)

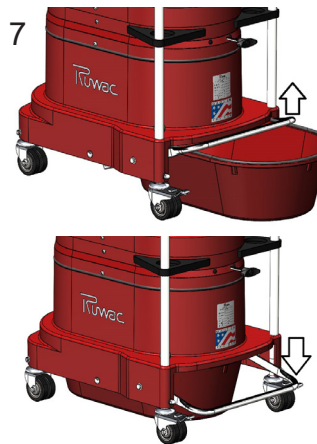

Carefully tip the machine back onto the casters, and replace the dustpan. Lock into position with the foot-actuated lever.

Note: Using an object to dislodge material may tear the filter. Consult your Ruwac representative if material blockage is excessive. Do not use high pressure compressed air or water to clean off filter, as material may become permanently lodged into filter membrane.

RED LINE STANDARD INSTRUCTIONS: FILTER INSTALLATION

WARNING: Always wear a dust mask when performing filter inspections or service.



1
Insert mesh inserts in filter pleats, and seat the filter in the housing.

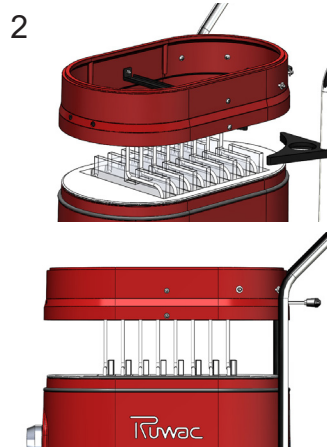

2
Place in the filter cage housing spacer assembly, making sure to keep the ground wire flat.

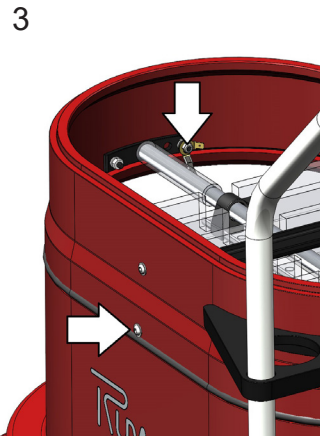

3
Connect the filter housing spacer assembly ground wire from the base via push on terminal.



4
Install the handle bar bracket screws with a 5/32 hex-wrench until the brackets are secure.

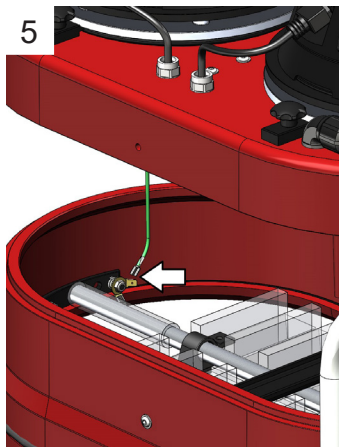

5
Connect the motor deck ground wire from the subsequent assembly via the push-on terminal.

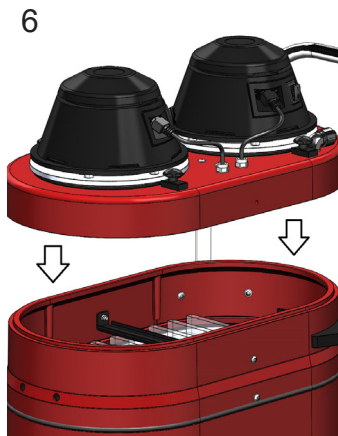

6
Place the motor deck onto the housing.

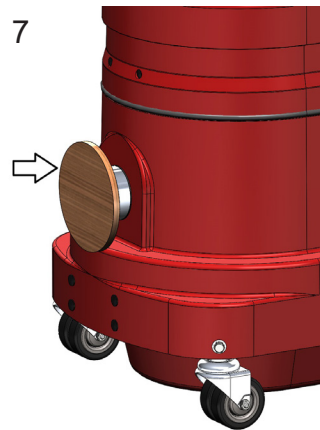

7
Place the vacuum under pressure by blocking the inlet with a flat and rigid material, and turn on the vacuum.



8
Install all of the hardware which secures the motordeck (both sides) while the vacuum is under pressure. Turn the machine off when done.

RED LINE STANDARD INSTRUCTIONS: HEPA MAXX FILTER MAINTENANCE

WARNING: Always wear a dust mask when performing filter inspections or service.



To ensure optimal performance of the HEPA Maxx filter, replace when the head loss reaches 8 inches of water column.



With motor running and inlet blocked, remove the motor deck hardware.



Remove the motor deck and disconnect the ground wire.

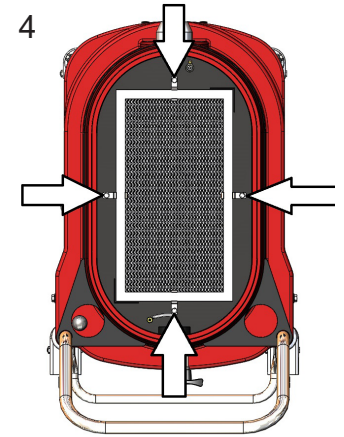

Loosen bracket hardware.

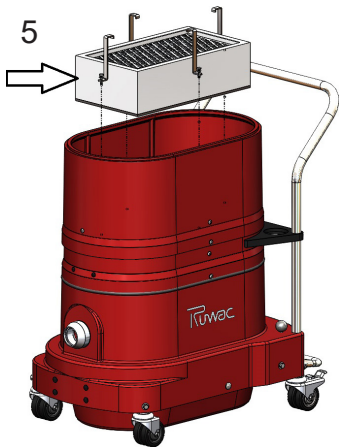

Remove and replace the HEPA Maxx filter.

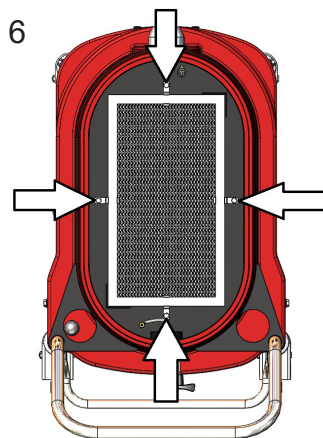

Tighten the bracket hardware.



Replace the motor deck, and attach the ground wire.



With the motor running and inlet blocked, secure the motor hardware.

RED LINE STANDARD INSTRUCTIONS: HEPA MAXX INSTALLATION

CAUTION: Motor deck will be heavy and may require two people to remove.



1
With motors running and inlet blocked, remove the motor deck hardware.

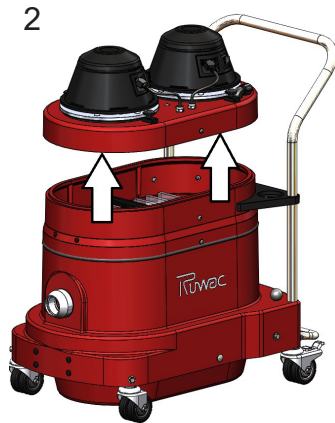

2
Remove the motor deck.

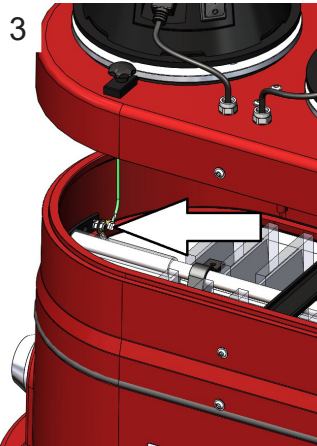

3
Disconnect the ground wire.



4
Insert M6 screws and hardware into the back of PEMs.



5
Place the HEPA Maxx module on the machine and connect the ground wire.

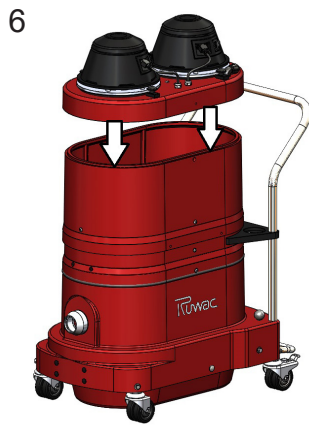

6
Place the motor deck on top of the HEPA Maxx module and connect the ground wire.



7
Turn on the motors and block the inlet.



8
Drill holes into the housing with a 5/16in bit. There are three locations on each side.

**RED LINE STANDARD INSTRUCTIONS:
HEPA MAXX INSTALLATION**

CAUTION: Motor deck will be heavy and may require two people to remove.



Remove the motor deck and drill out holes with a 1/2in bit. There is one location on each side.

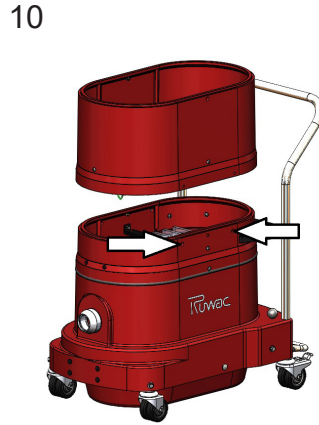

Lift the HEPA Maxx module and drill out holes with a 1/2in bit. There are two locations on each side.

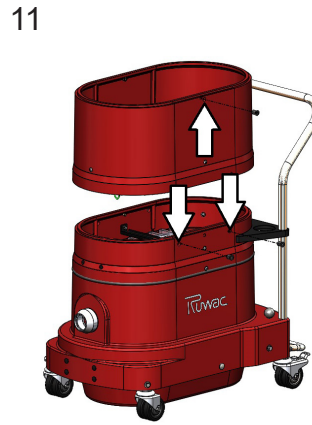

Insert rubber PEMs into the 1/2 inch holes. There are three locations on each side.



Replace the motor deck.

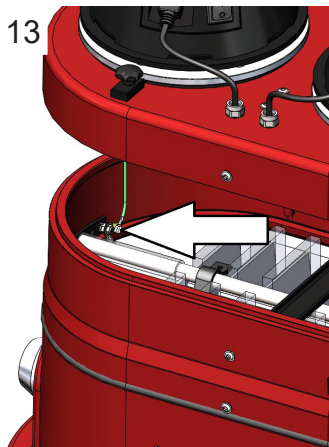

Reconnect the ground wire.



Block the inlet and turn the motors on.

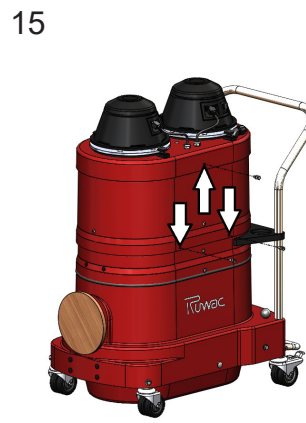

Insert the 1/4-20 bolts and lock washers into the rubber PEMs.



Complete unit as shown.

**RED LINE STANDARD INSTRUCTIONS:
HEPA 2.0 INSTALLATION**

WARNING: Always wear a dust mask when performing filter inspections or service.



1 Remove the motordeck from the filter ring.

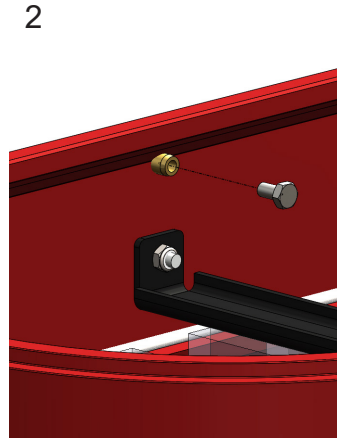

2 Plug the PEMs with short bolts.



3 Add the HEPA 2.0 space ring.

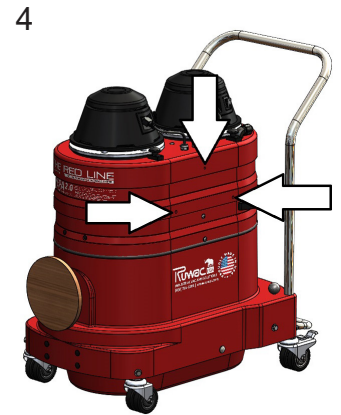

4 With the inlet blocked and motors running, transfer the holes using a 5/16" bit (3 holes each side).

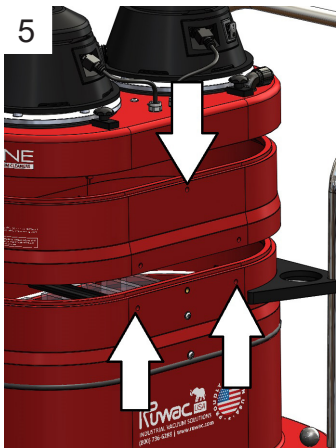

5 Open up three holes using a 1/2" bit (two holes on filter ring, one hole on HEPA 2.0 ring both sides).



6 Insert the rubber PEMs into 1/2" holes.



7 For WNS motordecks, pinch and insert the brackets into the bottom of the aluminum motorheads.



8 For WS motordecks, pinch and insert brackets into the vacuum inlets into the vacuum inlets on the bottom of the motordeck.



9 Install the filter and hardware. Tighten standard nut first, then add the locknut to ensure assembly doesn't come loose.



10 Install the motordeck.

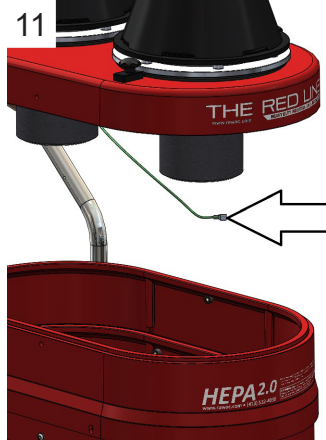

11 Be sure to attach the ground wire.



12 With the inlet blocked and motors running, install the hardware.

**RED LINE INSTRUCTIONS:
FLOOR SWEEP INSTALLATION**

STANDARD INSTRUCTIONS:

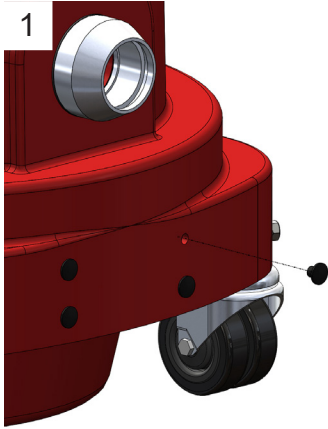

Remove the four plastic plugs from the mounting holes.

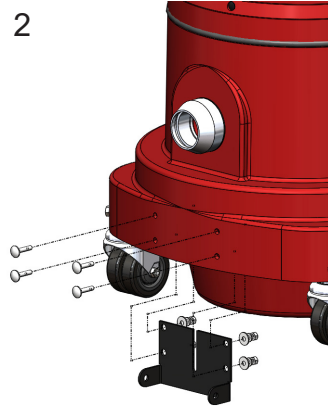

Install the mounting bracket and hardware as shown.

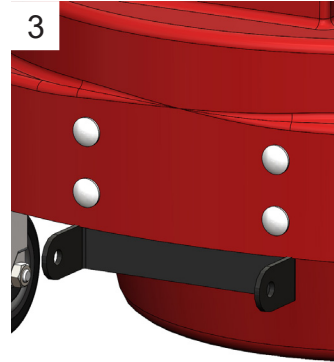

Mounting bracket should be behind housing, with tabs facing out.

DIRECT BAGGER INSTRUCTIONS:



Floor sweep mounting assembly attaches to the front of frame.

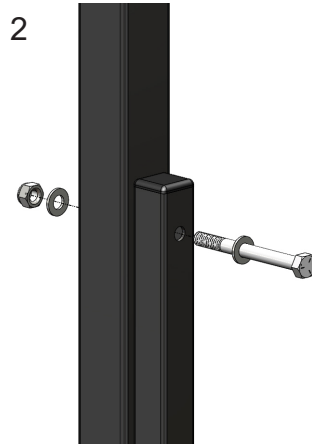

Use the included hardware as shown.



Check that all the hardware is securely fastened before operating with floor tool.

**R200 SERIES ONLY STANDARD INSTRUCTIONS:
WNS MOTOR COVER DISASSEMBLY FOR BRUSH INSPECTION**



Turn the machine off, then disconnect the power source.



Disconnect motor terminal.

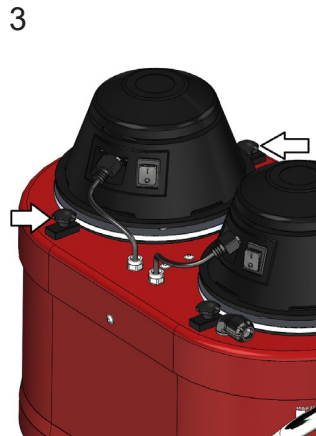

Loosen the motor retaining knobs enough to remove motor under negative pressure.

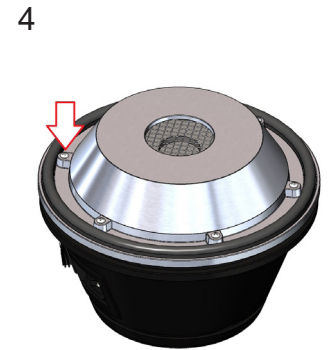

Remove the 6 screws attached to each motor assembly.



Remove the plastic motor cover to access the top of the motor.

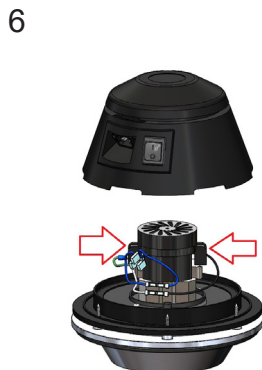

Remove the 2 metal motor-cap-retaining clips locating on each motor **(for Ametek motors only)**

**SEE PAGE 12 FOR
AMETEK
MOTOR BRUSH
INSPECTION
INSTRUCTIONS**

**SEE PAGE 13 FOR
ELECTRO MOTOR
MOTOR BRUSH
INSPECTION
INSTRUCTIONS**



**R210 SERIES ONLY STANDARD INSTRUCTIONS:
WS MOTOR COVER DISASSEMBLY FOR BRUSH INSPECTION**



Turn the machine off, then disconnect the power source.

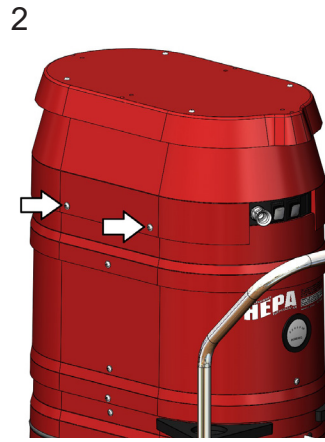

Disconnect hood from motor deck by removing 4 screws.

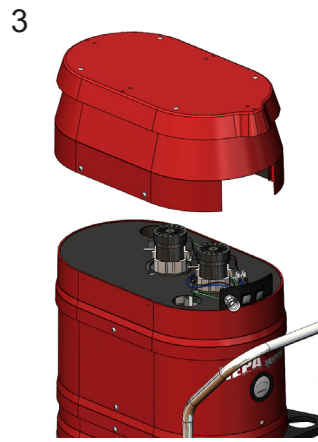

Remove silencer hood from motor deck.

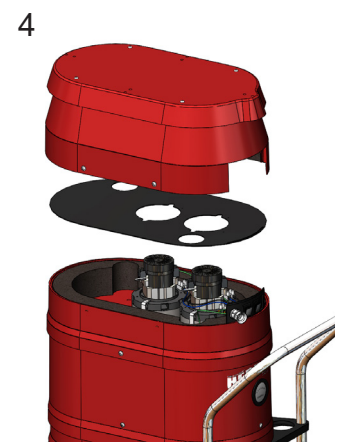

Lift motor shield up from deck to expose motors.

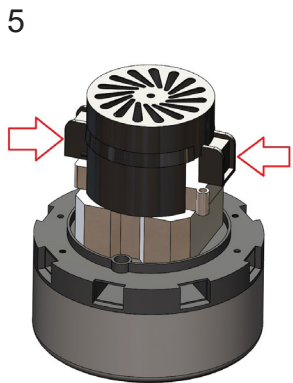

Remove the 2 metal motor-cap-retaining clips locating on each motor **(for Ametek motors only)**

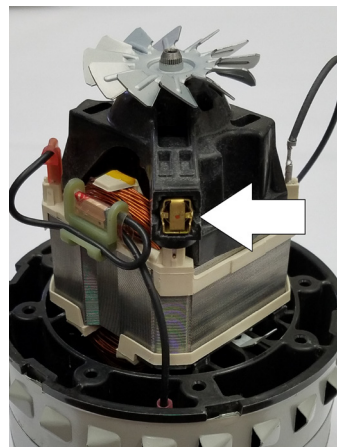

Electro brush

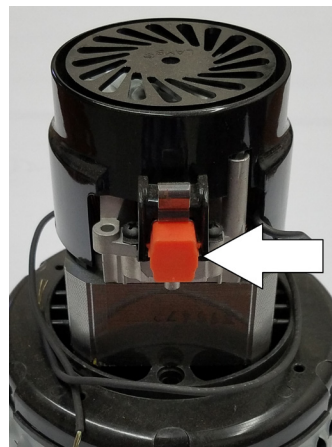

Ametek brush

**SEE PAGE 16 FOR
AMETEK
MOTOR BRUSH
INSPECTION
INSTRUCTIONS**

**SEE PAGE 17 FOR
ELECTRO
MOTOR BRUSH
INSPECTION
INSTRUCTIONS**

**RED LINE STANDARD INSTRUCTIONS:
AMETEK MOTOR BRUSH INSPECTION**

NOTE: A motor brush should be replaced if its length is less than 0.25 inches.

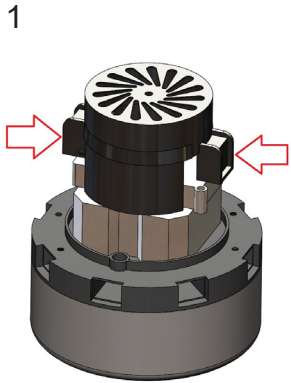

Remove motor fan cover by pressing down on clips located on each side.

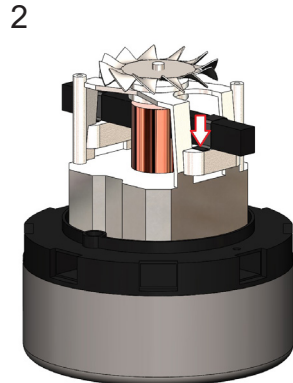

Remove the two screws securing the brush. Repeat the process for the other side.

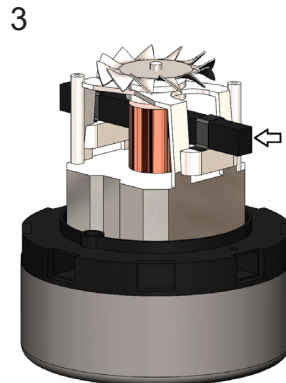

Pull brush out from wire clip.

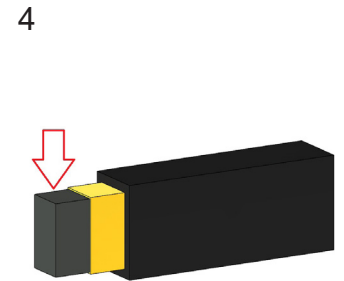

Remove brush from wire clip by sliding off groove. If brush is worn down to a length of 0.25" or less, replace brush.

To replace or reinstall brush, repeat process in reverse.

NOTE: Consult the WNS & WS Series parts manual (available at www.ruwac.com) for help identifying the specific replacement brush required for your machine.

RED LINE SERIES STANDARD INSTRUCTIONS: ELECTRO MOTOR BRUSH INSPECTION

NOTE: A motor brush should be replaced if its length is less than 0.25 inches.

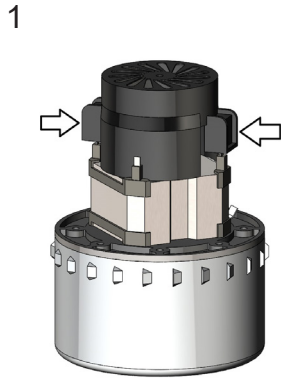

Carefully dislodge the plastic motor cap via the built-in hooks on both sides of motor brush. (**TIP:** Dislodge one side of a cap first followed by the other.)

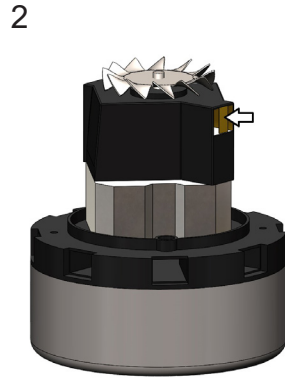

With a flathead screwdriver, flip brush tab upward. Use pliers to then pull the brush out by the tab.

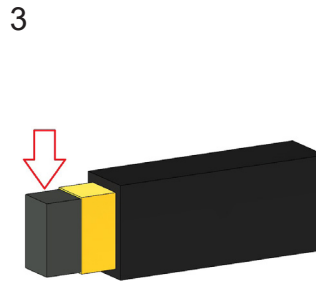

If the brush is worn down to a length of 0.25" or less, replace the brush. To replace or reinstall brush, hold down internal spring using the tool supplied with brush.

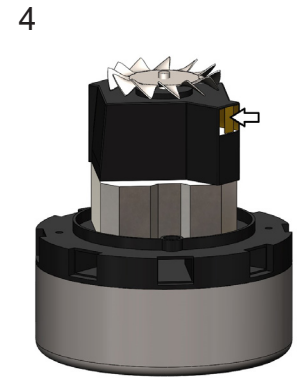

While holding spring down, push the brush back in. Remove the brush tool once the brush is in.

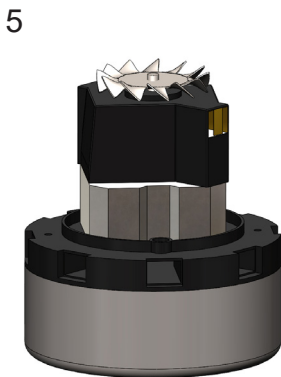

Push the motor brush in until it's flush.

NOTE: Consult the WNS & WS Series parts manual (available at www.ruwac.com) for help identifying the specific replacement brush required for your machine.

**RED LINE DIRECT BAGGING SERIES INSTRUCTIONS:
BAG-TO-VALVE ATTACHMENT & EMPTYING**

During operation, the Direct Bagger valve is kept closed by the negative pressure in the vacuum. When the vacuum is turned off, the valve will open and empty the contents of the vacuums into the attached plastic bag. An adjustable counter weight is located on the valve actuator. This weight may require adjustment depending on the material being dumped into the bag. A thumb screw is located on the counter weight. If the material is not being dumped into the bag once the vacuum is full, then reposition the counter to react to the weight of the material inside. Remove safety pin prior to use, otherwise gravity drop will not seat properly.

Note: The Direct Bagger valve is located below the vacuum producer.
Two bag clamps are located to each side of the valve. Each clamp has a red handle.

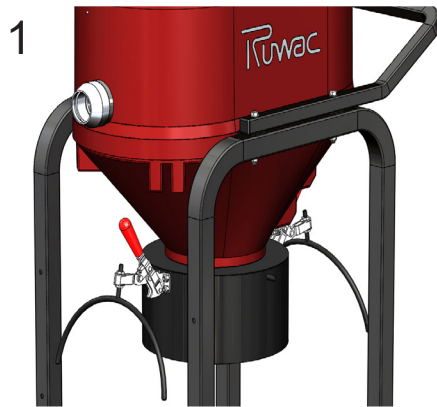

1 Move each handle into the up position (handle above horizontal position.) This moves the bag clamp away from the valve.



2 Open the plastic bag fully (less folds in the bag will allow the bag fill easier.) Wrap the opening of the bag as shown in picture, and close the clamp by lowering the red clamp handle.



3 Wrap the second half of the bag around the valve and close the second clamp.

To remove the bag, tie off the bag with a zip tie or wire tie before you open both clamps.

PROBLEM	POSSIBLE CAUSE	CORRECTIVE ACTION
Insufficient Vacuum Pressure	- Motors are not on and/or working	- Turn both motors on, check motor brushes
	- Dustpan improperly seated	- Remove dustpan, inspect seal, replace dustpan.
	- Filter clogged or improperly seated	- Follow filter inspection procedure, section IV.
	- Clogged hose	- Remove hose and re-inspect vacuum pressure, if vacuum pressure returns to normal snake hose.
	- Unit is improperly sealed	- Block the inlet with a flat and rigid material to place the unit under vacuum pressure then inspect for air leaks.
Air Leaks	- Worn or poorly seated seals, Retainers improperly installed	- Block the inlet with a flat and rigid material to place the unit under vacuum pressure then remove retainers and turn the unit off. Inspect the seals for completeness, then reseal and secure components again under vacuum pressure.
Material In Exhaust / On Top Side of Filter	- Poor filter seal or torn filter	- Follow filter inspection procedure, section IV.
Unusual or High Pitched Noises	- Motor bearings, Motor bushings	- Follow relevant motor bushing inspection procedure, section IV. Check motor bearings for noise by hand.
	- Worn or poorly seated seals, Retainers improperly installed	- Block the inlet with a flat and rigid material to place the unit under vacuum pressure then remove retainers and turn the unit off. Inspect the seals for damage, then reseal and secure components again under vacuum pressure.



LIMITED WARRANTY: RUWAC warrants that new equipment which are complete units and are sold and/or manufactured by RUWAC, Inc. will be free from defects in material and workmanship for a period of 18 months from date of shipment or 12 months from date of start-up, whichever comes first. RUWAC warrants that replacement parts sold hereunder will be free from defects in material and workmanship for a period of 120-days after the date of shipment. RUWAC machines that have been completely re-built at the factory will carry a 180-day warranty from date of shipment. All field repairs by authorized RUWAC service personnel are covered by a 120-day parts only warranty. RUWAC, Inc. will not assume any responsibility under the terms of this limited warranty on equipment, which have not been paid for in full. This warranty does not apply to any equipment that has been disassembled, repaired, or otherwise altered by any person without the written authorization of RUWAC'S service department, nor does it apply to any product that has been subject to failure due to corrosive or abrasive attack, misused, damaged, or improperly installed, nor does it apply to motors, controls, and components not manufactured by RUWAC, Inc. Motors, controls, and other Sub vendor's components therefor are warranted only to the extent of the manufacturer's warranty. All warranty work on such products must be authorized by RUWAC, Inc. and must be performed in an authorized shop as designated by the manufacturer. RUWAC sole liability and buyer's sole and exclusive remedy hereunder is the replacement or repair at RUWAC'S option of products not complying with this warranty. Such repair or replacement shall be F.O.B. RUWAC'S factory, and RUWAC reserves the right to invoice all expenses incurred when repairs are made in the field at the request of the customer, except as specifically set forth herein, RUWAC makes no warranty express or implied, with respect to the products and/or service supplied hereunder, this warranty is in lieu of and excludes all other warranties, including without limitation, any warranty of merchantability, fitness for a particular purpose, or conformance to purchaser's specifications.

LIMITATION OF LIABILITY: RUWAC'S responsibility with respect to the goods and RUWAC'S obligations related thereto should in no event exceed the purchase price of the goods. RUWAC shall not be liable to Buyer for any special incidental, indirect, or punitive damages for any reason whatsoever, including, but without limitation damages in the form of (a) loss of profits, revenues, or anticipated savings resulting from the failure of the equipment to meet specifications or warranties (b) damages suffered by Buyer as a result of loss of production facilities or equipment (c) cost of replacement equipment (d) damages suffered by customers of the Buyer (e) any fines or penalties assessed for failure to comply with any law or government regulations.

REPAIR OF GOODS EXPOSED TO HAZARDOUS, TOXIC, OR INFECTIOUS MATERIAL: Buyer shall ensure that any goods submitted by Buyer or any of its customers to RUWAC for repairs or other service have been decontaminated and cleaned (including sterilization, if appropriate) of any hazardous, toxic or infectious materials, including without limitation any materials listed by the Environmental Protection Agency, OSHA, or any applicable state law as deserving or requiring special treatment. Upon RUWAC'S request, Buyer or its customer shall certify in writing that such goods contain no such hazardous, toxic, or infectious materials, and that such decontamination has taken place in accordance with accepted parties and in accordance with all applicable laws and regulations. If special safety equipment is required to protect RUWAC'S service personnel from any such hazardous, toxic, or infectious materials during field service work or otherwise. Buyer shall ensure that such safety equipment is provided and that the personnel are properly instructed. The provision of this paragraph shall apply to all work to be performed by RUWAC'S service personnel at any time, whether or not covered by warranty. Buyer shall defend and indemnify RUWAC for any and all losses, liabilities, expenses, and damages (including attorneys' fees) arising out of any failure of buyer or its customer to comply fully with the terms of this paragraph.

BUYER SUPPLIED DATA: Buyer acknowledges that RUWAC has relied upon all specifications and other data supplied by Buyer to RUWAC in the selection and design of the equipment and the preparation of this proposal. In the event the site operating conditions differ from those represented by Buyer and relied upon by RUWAC, any warranties or performance guarantees contained herein affected by such conditions shall be null and void, unless otherwise mutually agreed upon in writing.

REMEDIES OF SELLER: In addition to any other remedies of RUWAC provided hereby or by law, in the event Buyer becomes bankrupt, insolvent, assigns assets for the benefit of creditors or its financial condition has substantially deteriorated, RUWAC may, at its sole option, declare a breach of contract, stop all work hereunder or demand payments in advance as security for its performance hereunder.

FACTIONS: GOVERNING LAW: Any dispute, controversy, or claim against RUWAC with respect to the goods or any of RUWAC'S obligations related thereto must be commenced within one year from the date of shipment. All contract between Buyer and RUWAC shall be governed by and construed in accordance with the laws of the state of Massachusetts except that body of laws controlling conflict of laws.

BONDS: In addition to the price specified herein, Buyer shall pay the cost of any bonds, which Buyer requires RUWAC to obtain.

ENTIRE AGREEMENT: These terms and conditions, together with the provisions of the proposal constitute the entire agreement between the parties pertaining to the goods, and they supersede any prior or contemporaneous agreements, representations, or understandings between the parties. No waiver or modification of these terms and conditions is binding unless such waiver or modification is set out in writing signed by an authorized manager or officer of RUWAC. RUWAC'S failure to strictly enforce any right on one occasion does not constitute a waiver of that or any on any other occasion.

ALSO AVAILABLE FOR YOUR VACUUM NEEDS...



**CENTRAL VACUUM
SYSTEMS**



**THREE PHASE
CONTINUOUS DUTY**



**CERTIFIED
EXPLOSION PROOF**



54 Winter Street
Holyoke, MA 01040
(800) 736-6288
info@ruwac.com
www.ruwac.com



ADDITIONAL ACCESSORIES & OPTIONS

All of Ruwac's industrial vacuum cleaners are compatible with a wide variety of accessories.

We offer many tools such as vacuum floor tools, nozzles, hoses and more individually or in accessory packages, as well as vacuum options such as our HEC Cyclone Pre-Separators and HEPA / ULPA filter upgrades.

General Purpose Accessory Kits

Available in 1.5" and 2" ID collections, these kits include hoses, tools and are ideal for use with light duty application vacuums.



Additional Hose Lengths

Do you need a longer or wider hose? Ruwac offers a selection of hoses in all sizes and materials to ensure your vacuum system can handle removing any material!



Overhead Cleaning Kits

Need to get to a hard to reach spot? This kit includes wands and tools for overhead cleaning. When both wands are connected, they reach over 10 ft. in height!

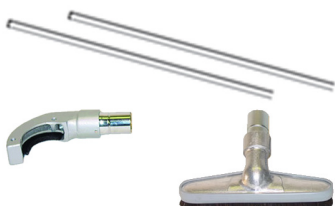

Cyclone Pre-Separators

Collect 97% of debris before reaching the vacuum with Ruwac's HEC - High Efficiency Cyclone. Increases filter life. 30 & 55 gallon drums available with tipping and forklift pockets makes emptying easy. Best of all, they're very portable.



Floor Tools & Nozzles

Ruwac's wide range of vacuum tools and kits give you the quick assist when removing whichever materials may be in front of you. We offer wands, floor tools, nozzles and more so that an easy clean-up can become even easier!

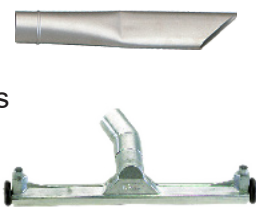

HEPA & ULPA Upgrades

Modular housing allows for upgrades to HEPA or ULPA filtration at any time, to collect and contain debris down to and including 0.3 or 0.1 microns, respectively.



LOOKING FOR SOMETHING ELSE?

REQUEST AN ACCESSORIES CATALOG TO SEE OUR FULL LINE OF OFFERINGS TODAY!

